

Wilsonart® Decorative Edge Fabrication Manual

 Wilsonart® Decorative Edges

Wilsonart® Decorative Edges

Product Description

Wilsonart Decorative Edge moldings may well be the best way to attain leading-edge kitchen and bath design without a leading edge budget.

The simple addition of decorative moldings can transform an ordinary laminate countertop into a real design statement, by eliminating the brown line and adding literally millions of design options. In fact, our beveled laminate moldings are available in over 200 solid colors and patterns. Cascade and Crescent laminate are available in HD, Milano (#52 finish), and Madura (#52 finish) patterns and finishes. Our wood moldings are made of hand-selected solid hardwood. Check availability for each specific decorative molding design.

The Decorative Edge concept is a simple one. So simple that thousands of qualified fabricators across North America are creating custom looks with laminate-clad Decorative Edge moldings everyday. They are so durable we've given them a ten-year limited warranty against face edge delamination.

So if you're building or remodeling a kitchen or bath, Decorative Edge moldings are the affordable design option you just can't afford to overlook.

- **Bevel Moldings (FE-Flat Edge and SE-Snap Edge):**
The Bevel Edge creates a sleek, seamless look. The two planes of the molding may be specified with the same laminate as the top, for a monolithic effect, or in coordinating and contrasting colors or patterns (choose from over 250 Wilsonart Laminates).
- **Cascade (FE-Flat Edge and SE-Snap Edge):**
The Cascade Edge pairs a flowing waterfall roll with a straight-edged base for a look that is naturally beautiful and impressive.
- **Crescent (FE-Flat Edge and SE-Snap Edge):**
The Crescent Edge invites the eye and warms up decor with soft curves at top and bottom.
- **Wood Moldings:**
The Decorative Edge Wood Moldings are the way to add the warm, hand-crafted look of wood to your kitchen or bath. They're offered in three profiles of standard stock in Red Oak, and Hard Maple. However, any wood species is available. Radius Corner Moldings are available in 2", 4" and 6" in Red Oak and Hard Maple. Radius Corner Moldings and wood moldings can be grooved to accept a laminate or metal insert.

GUARANTEED TEN YEARS

Unlike some molding products, laminate-clad moldings are made with medium density fiberboard (MDF), to which decorative laminate is bonded. Because of this assembly technique, it's practically impossible for the face edge of the molding to delaminate. In fact, we have so much confidence in the performance of laminate-clad moldings we back them with a ten-year warranty against face edge delamination. See your distributor of Wilsonart products for complete details.

SAFETY

Safety should be a critical concern for any fabrication shop. Good safety practice can lower your insurance rates - but most important, they will keep you and your colleagues injury-free and on the job.

Wear safety glasses with side shields when you are cutting or routing. Do not take chances with flying chips and fragments.

The edge of Wilsonart Laminate moldings are razor sharp. Although they probably would not cause a serious injury, why risk painful cuts when a good pair of work gloves can protect your hands?

We also recommend using ear protection - ear plugs or ear muffs - whenever you are operating power tools. It can help prevent permanent hearing damage.

STORAGE

Keep Decorative Edges in packaging tubes until ready to fabricate. Moldings are packaged in a plastic sheath and a cardboard tube. It is best to store the moldings in this packaging to eliminate warping and possible damage to the molding.

Wilsonart® Decorative Edges

Tool Kit

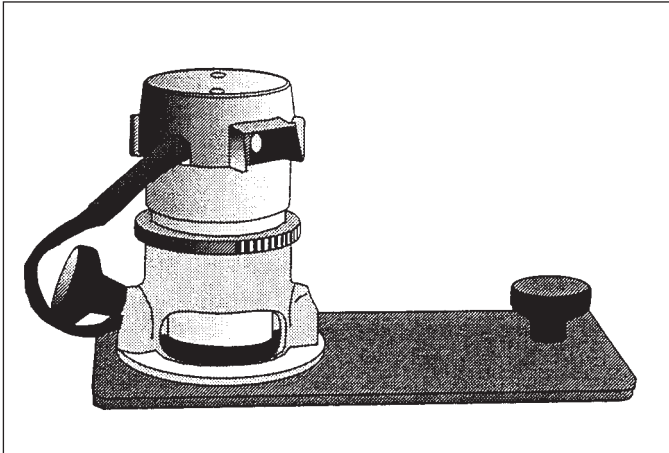

1/4" Dado Cutter

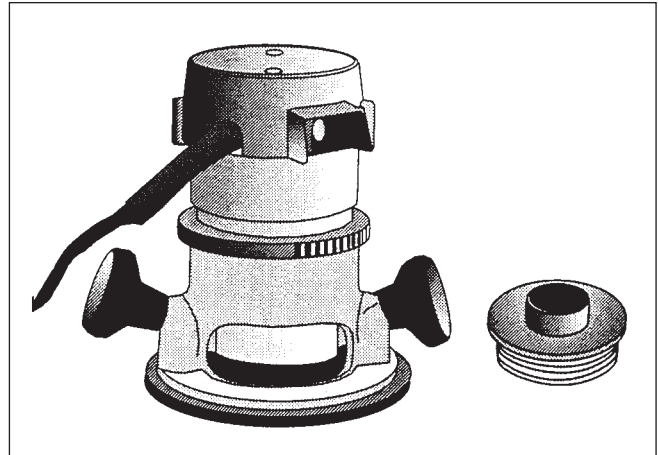

Clipped Corner Router and
Template Guide

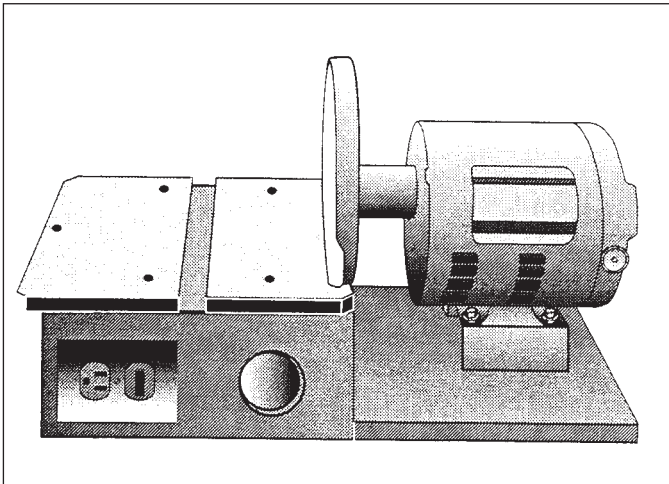

10" Disk Sander

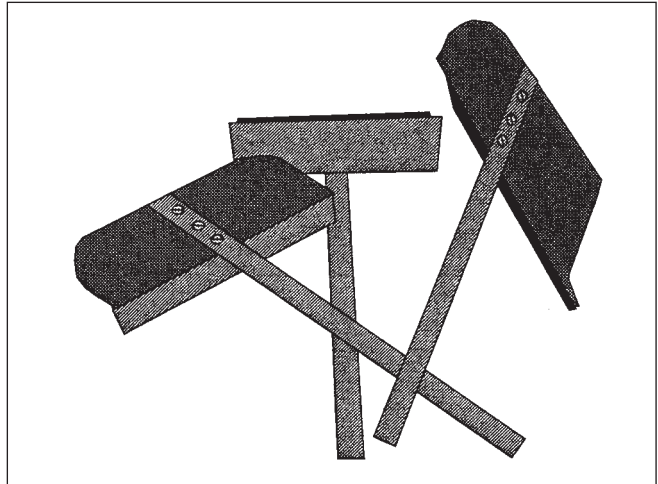

90°, 45°, 22-1/2° Miter Gauges

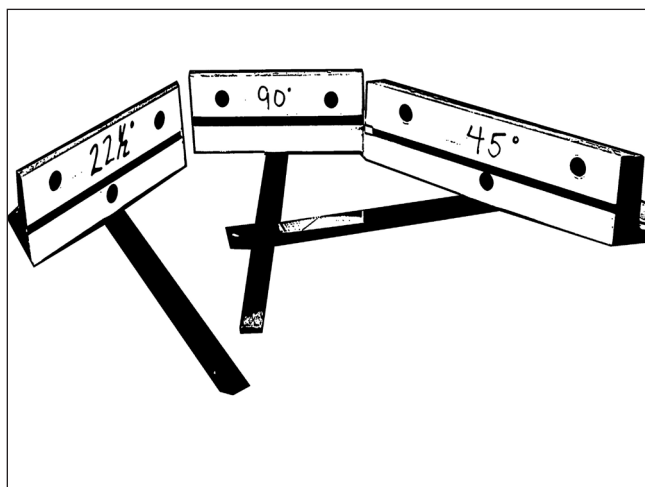

90°, 45°, 22-1/2° Phenolic Attachment Plates

Wilsonart® Decorative Edge Phenolic Plate Attachments

Design for use with Cascade and Crescent SE Mounting styles.

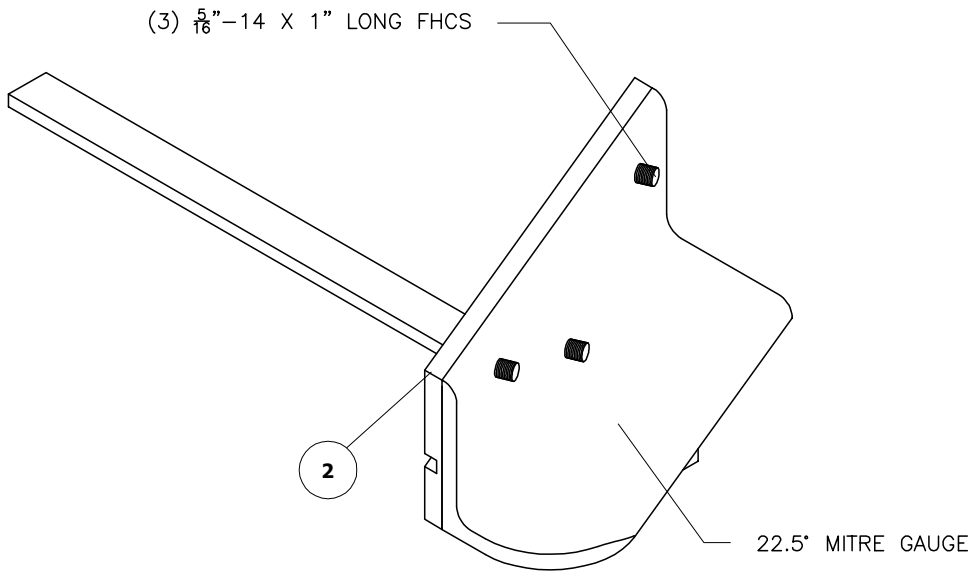

22.5° MITRE GAUGE
ASSEMBLY VIEW
NTS

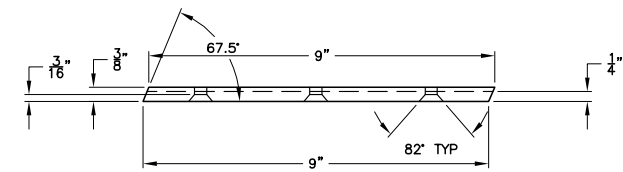

22.5° PHENOLIC GUIDE
TOP VIEW
MATERIAL: $\frac{3}{8}$ " COMPACT LAMINATE

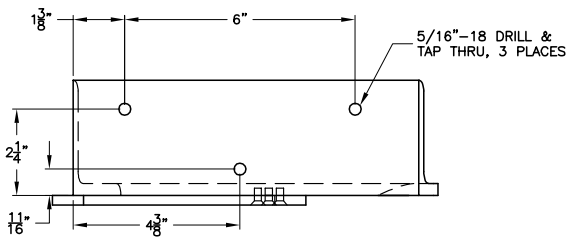

22.5° HOLE LOCATION
FRONT VIEW

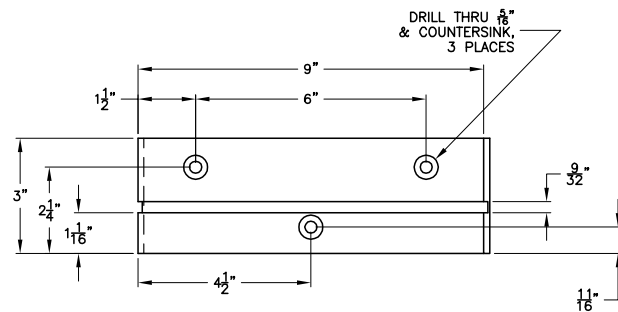

22.5° PHENOLIC GUIDE
FRONT VIEW
MATERIAL: $\frac{3}{8}$ " COMPACT LAMINATE

Wilsonart® Decorative Edges

Phenolic Plate Attachments

Design for use with Cascade and Crescent SE Mounting styles.

(3) $\frac{5}{16}$ "-14 X 1" LONG FHCS

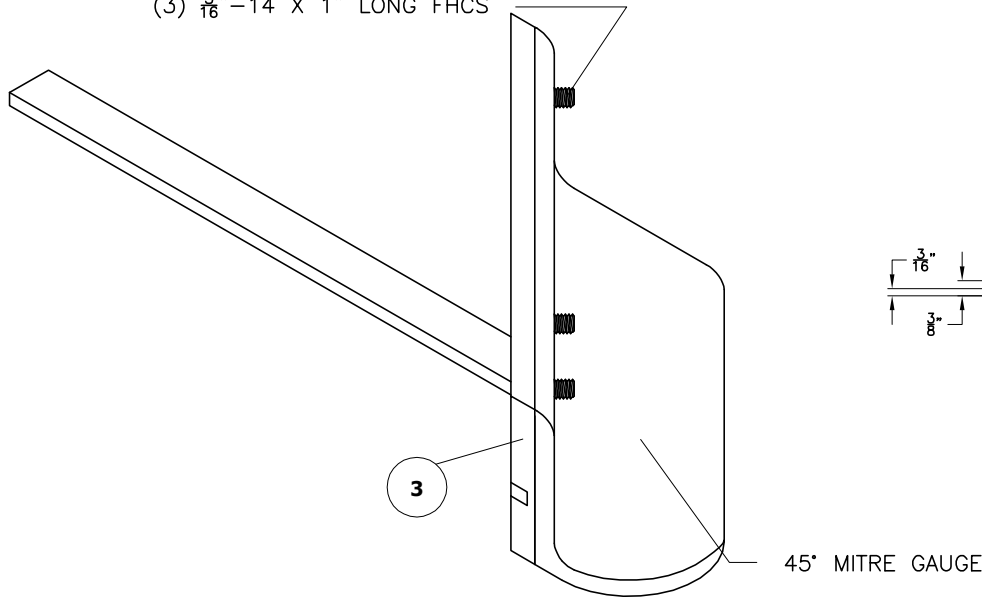

45° MITRE GAUGE
ASSEMBLY VIEW
NTS

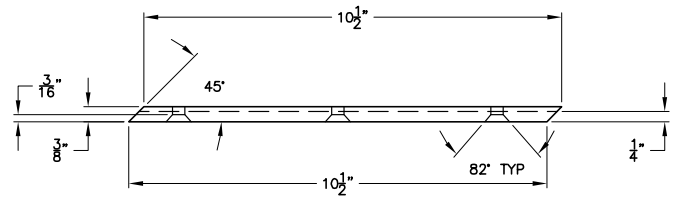

45° PHENOLIC GUIDE
TOP VIEW
MATERIAL: $\frac{3}{8}$ " COMPACT LAMINATE

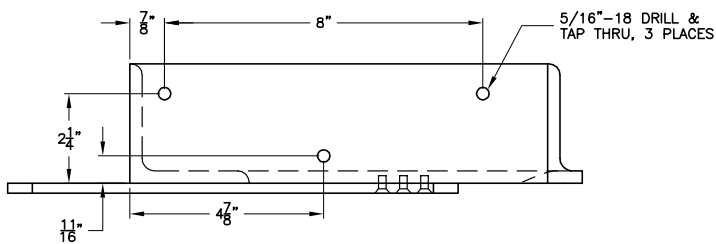

45° HOLE LOCATION
FRONT VIEW

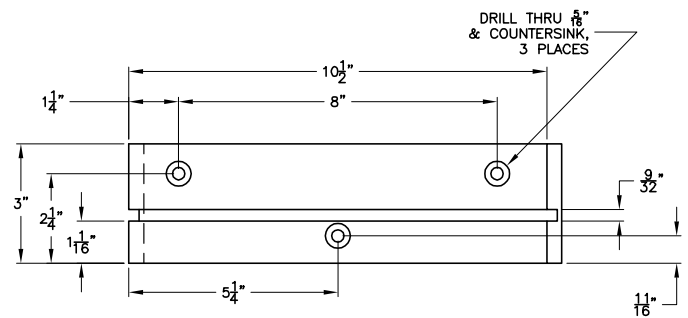

45° PHENOLIC GUIDE
FRONT VIEW
MATERIAL: $\frac{3}{8}$ " COMPACT LAMINATE

Wilsonart® Decorative Edge Phenolic Plate Attachments

Design for use with Cascade and Crescent SE Mounting styles.

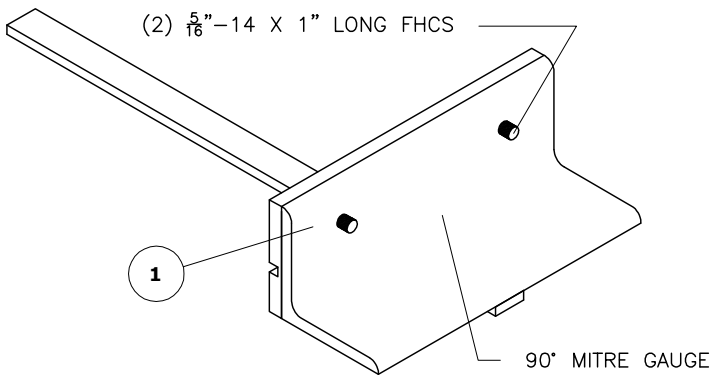

90° MITRE GAUGE
ASSEMBLY VIEW

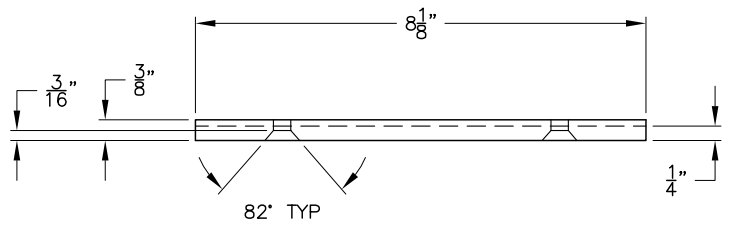

90° PHENOLIC GUIDE
TOP VIEW
MATERIAL: 3/8" COMPACT LAMINATE

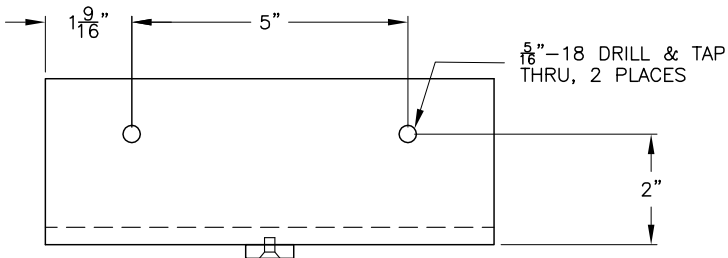

90° HOLE LOCATION
FRONT VIEW

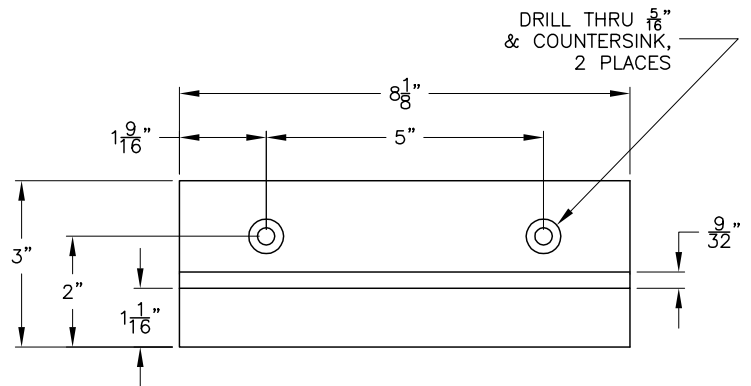

90° PHENOLIC GUIDE
FRONT VIEW
MATERIAL: 3/8" COMPACT LAMINATE

Wilsonart® Decorative Edge

Fabrication

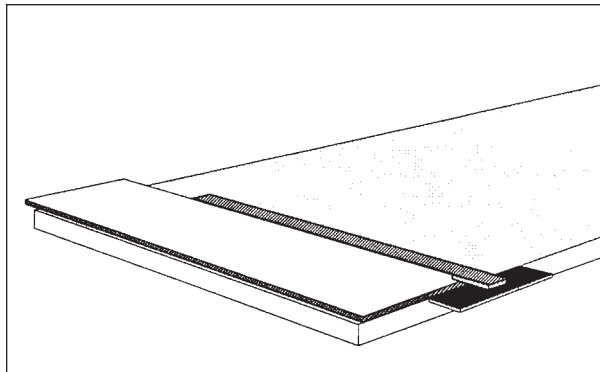

FIGURE 1

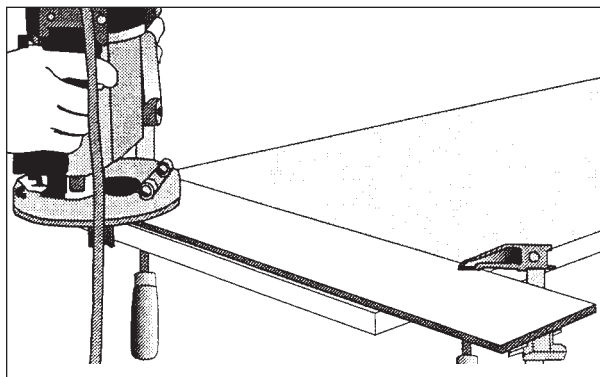

FIGURE 2

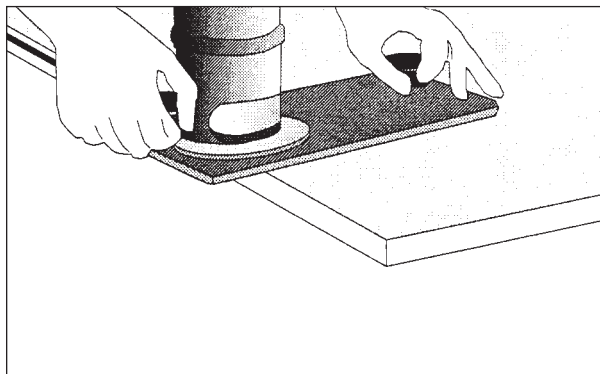

FIGURE 3

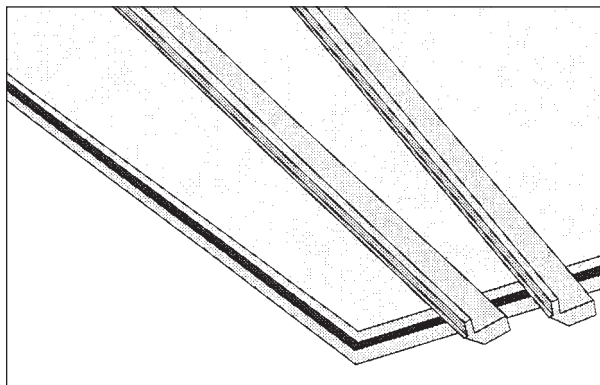

FIGURE 4

Cut the substrate to the desired size, (top should be 1/8" larger) place the substrate face side up on a flat work surface and thoroughly brush the substrate surface clean.

STEP 1

Place a 90° miter gauge on the front of the countertop. Place straight edge against miter gauge and align along the edge of the countertop. Hold the miter gauge firm against counter, check the straight edge to see if it is flush with the countertop edge. If the straight edge is flush with your countertop, the countertop is square. If not, back the straight edge up approximately 1/8" keeping it square against the miter gauge. (FIG. 1) Clamp the straight edge into place.

NOTE: If countertop is square, without inside corners, use the Decorative Edge straight cut planner to plane the edge. (Proceed to Step 3).

STEP 2

Clamp straight edge to the edge that is to receive molding. Use a router with 2 flute cutter and template guide. Working left to right, trim off approximately 1/16" from the countertop. Do the same for all edges to receive bevel molding. (FIG. 2)

NOTE: Exercise care to assure a chip free machined edge surface.

STEP 3

When using SE-style moldings, use the 1/4" Dado Cutter to machine the dado into the substrate. Always rout in a left to right direction, using a smooth consistent motion. (FIG. 3)

NOTE: When using FE-style molding, it is recommended to attach build-up support strips to the countertop prior to dry-fitting moldings. Build-up strips must be flush with edge of countertop. Support strips are required when using Crescent moldings.

STEP 4

Measure the substrate edges and rough cut the molding pieces (working in a right to left direction). Leave at least three quarters of an inch (3/4") of excess on both ends of the molding piece. (FIG. 4)

STEP 5

When sanding the mitered edges for Bevel SE-style moldings, start with the molding laminate side to the miter gauge with the bevel side up, sand the edge to a miter. Alternate the molding - bevel up/bevel down - for each miter. Always keep the laminate side to the miter gauge.(FIG. 5)

NOTE: Inside corners will cause you to change the direction of the miter gauge on the disk sander.

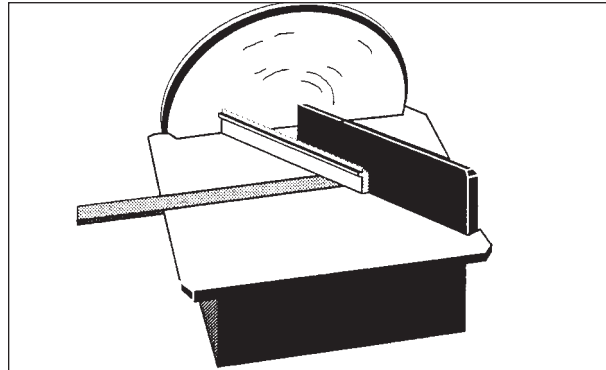

FIGURE 5

When sanding the mitered edges for Cascade SE and Crescent SE style moldings, use the modified miter gages with phenolic plate attachments (FIG. 6). Insert the 1/4" wood tongue of the SE molding into the dado slot in the phenolic plate attachment. Alternate the tongue up and down in the dado slot for each miter. Always keep the wood side to the miter gauge and phenolic plate (FIG.7)

NOTE: Inside corners will cause you to change the direction of the miter gauge on the disk sander.

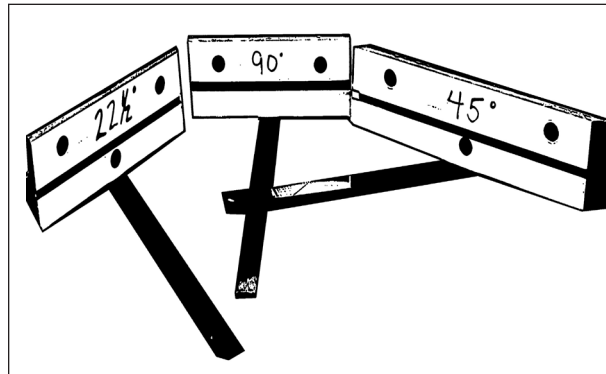

FIGURE 6

When sanding the mitered edges on the Bevel FE, Cascade FE and Crescent FE moldings use standard or modified miter gauges. Keep wood side of the molding to the miter gauge. Miter gauge on the left to create inside corners and miter gauge on right to create outside corners. Always keep the wood side to the miter gauge/phenolic plate.

STEP 6

Working right to left dry fit each molding. Use a white rubber mallet to dry fit SE-style moldings into the dado groove around the top of countertop. For FE-style molding, use filament tape.

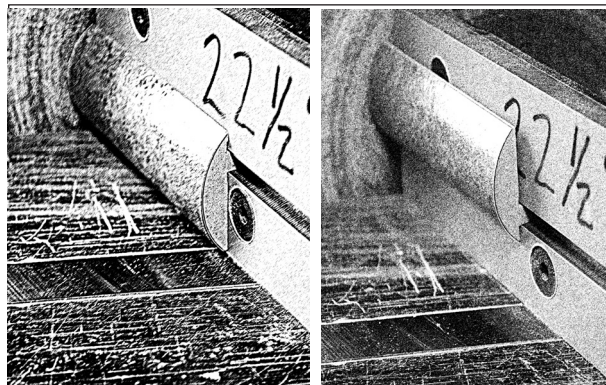

FIGURE 7

STEP 7

Use a sharp pencil to mark the miter position of your molding pieces. Repeat this step for each additional piece. (FIG. 8)

STEP 8

Sand your miters to the precise length you have marked, and brush all the molding pieces clean. Always use disc sander, not a miter saw, to finish all miters.

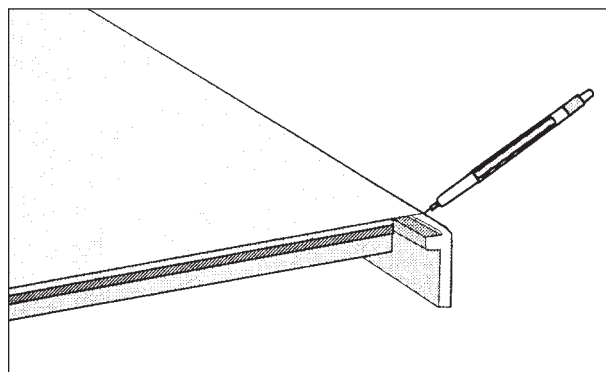

FIGURE 8

Wilsonart® Decorative Edges

Fabrication

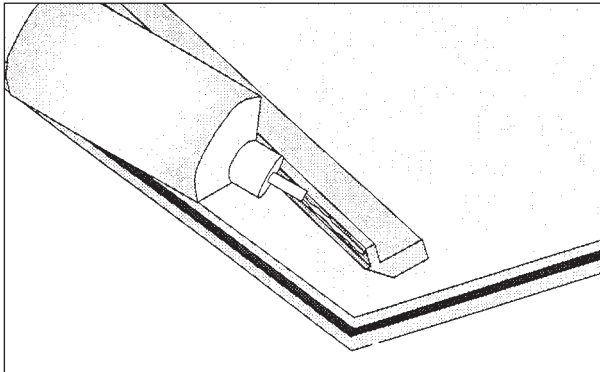

FIGURE 9

CAUTION: After dry fitting and scribing the moldings, carefully remove them and prepare moldings and countertop for adhesion.

STEP 9

Apply a bead of Wilsonart Type II adhesive to the top and bottom inside corner of the SE-style molding tongue. (FIG. 9 & 10)

NOTE: Excess squeeze-out provides no additional benefit and complicates clean up.

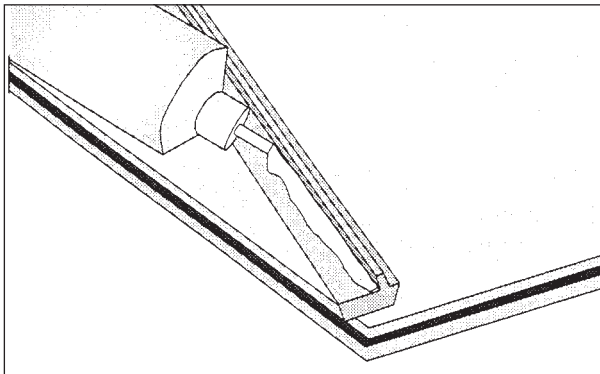

FIGURE 10

STEP 10

Smooth out the bead of Wilsonart Type II on the top of the tongue with the tip of your finger. (FIG.11)

When adhering FE-style molding apply a 1/4" bead of Wilsonart Type II adhesive and spread adhesive to the entire wood area of the FE molding.

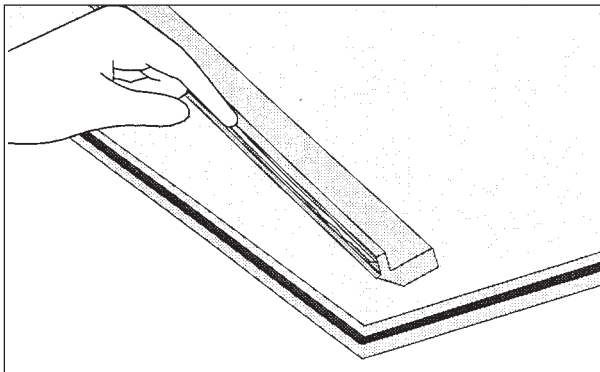

FIGURE 11

CAUTION: Use care not to slide your finger over the laminate edge of the molding. It is sharp and will cut your skin.

NOTE: You do not want any glue squeeze-out on the top of the molding. Glue squeeze out on top of the bevel may cause separation from the countertop. If squeeze out occurs wipe off with a damp cloth immediately.

STEP 11

Apply vertical strips of filament tape over the length of the molding every 3 - 4" to hold the molding in place until the adhesive dries. (FIG. 12)

NOTE: Apply the tape to the face of the molding using upward pressure.

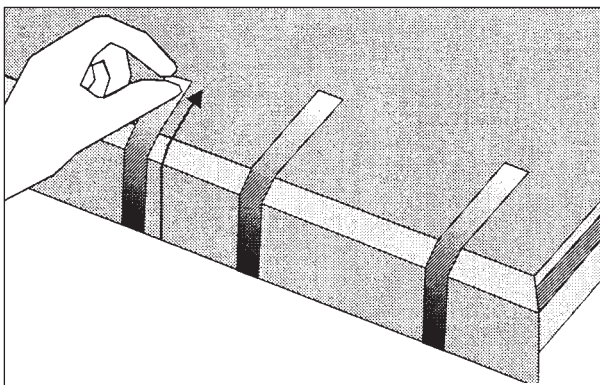

FIGURE 12

Fabrication

STEP 12

Put a small amount of Wilsonart Type II adhesive on the trailing end of each molding piece before installing it. Then, use filament tape to hold the corners in place while the adhesive dries (approximately 30 min.) (FIG. 13)

NOTE: Glue squeeze out on top of the bevel may cause separation from the countertop. If squeeze out occurs wipe off with a damp cloth immediately.

STEP 13

Recommended - turn the top over (face down) and add build-up/build-down strips to all exterior edges of the substrate that have received SE-style molding strip. (FIG. 14)

When using FE-style moldings, it is recommended to attach build-up support strips to the countertop prior to dry-fitting moldings. Build-up strips must be flush with edge of countertop.

NOTE: When using FE-style molding, it is recommended to attach build-up support strips to the countertop prior to dry-fitting moldings. Build-up strips must be flush with edge of countertop. Support strips are required when using Crescent moldings.

When adding the build-up/build-down strips, it is recommended that Wilsonart Type II and staples be used, to attach the strips.

CAUTION: Exercise care when selecting the length of the staple to be used when attaching build-up/build-down strips. Inappropriate length staple(s) will cause damage to the top surface.

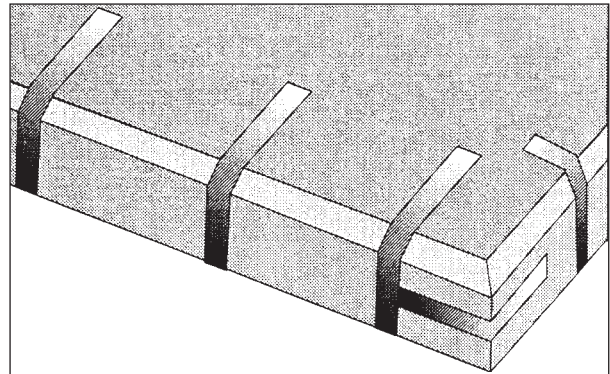

FIGURE 13

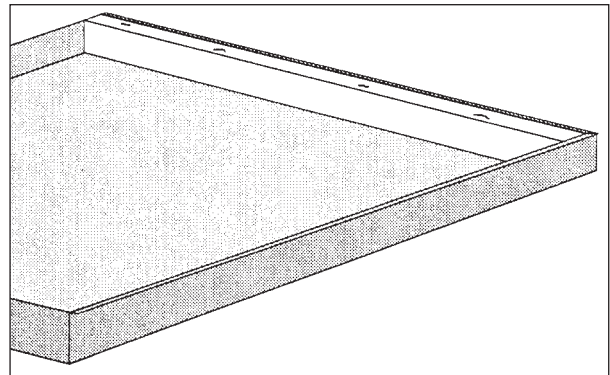

FIGURE 14

Wilsonart® Decorative Edges

Clipped Corners

Typically, the design for a custom built Decorative Edge Countertop will contain at least one 90° outside corner. Although these corners are cosmetically pleasing to the eye, a customer may request that you soften the 90° angle by “clipping” the corner(s). The following is an efficient and accurate method for clipping 90° outside corners on a pre-laminated top.

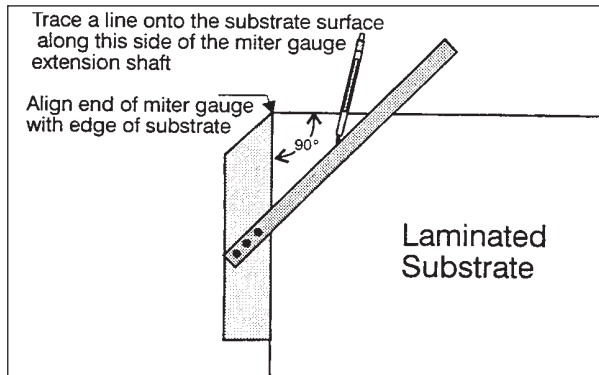

FIGURE 1

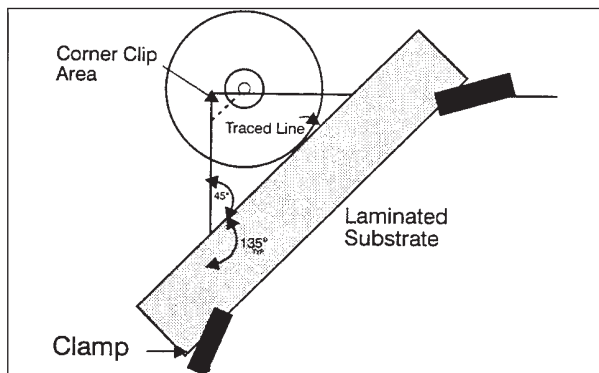

FIGURE 2

STEP 1

On pre-laminated substrate that contains a 90° outside corner. Use the Decorative Edge Straight Cut Planer to machine both substrate edges to which moldings will be fitted.

STEP 2

Invert 45° miter gauge and place onto the countertop. Align the end of the gauge with the edge of countertop (FIG. 1). Using a pencil, draw a line onto the countertop along the front edge of the miter gauge. This will establish the correct 45° at which to machine the “clipped” corner (FIG. 2).

STEP 3

Align straight edge on line and clamp.

NOTE: The 45° miter gauge accurately positions the pencil line so that the clip corner router can be used to machine the substrate.

CAUTION! This procedure is based upon the countertop overhanging the cabinet face by 1-inch on both sides of the corner. Additionally, the clip corner router is fitted with a special 6-1/2” diameter base plate. If you choose to use a router having a base diameter other than 6-1/2”, it is necessary to adjust the position of the traced line.

STEP 4

You are now ready to apply SE or FE-style moldings.

Follow steps in Fabrication Techniques for the Decorative Edge of your choice.

Clipped Corners - Building a Template

STEP 1

Construct a Template (FIG. 1) This can easily be accomplished by cutting 2-1/2" wide strips from 3/4" particle board that has been laminated on both sides. After cutting the strips to the appropriate lengths, align the longest strip against the drawn line (on the laminated substrate) and secure in place with standard laminate clamps. Use 1-1/4" Phillips head drywall screws to complete the Template assembly.

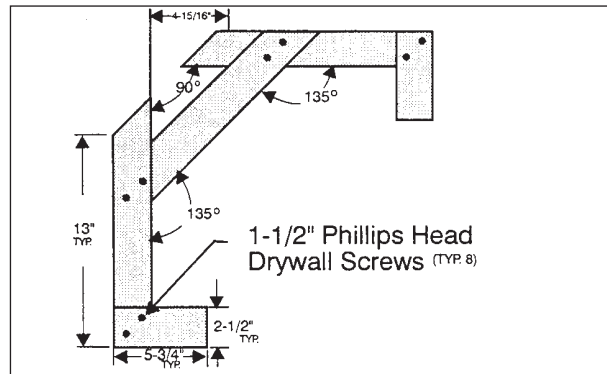

FIGURE 1

STEP 2

Position the Template onto your countertop substrate and secure in place using standard laminate clamps at the locations. (FIG. 2)

NOTE:

Machining through 3/4" countertop (with a 1/2" bit) can produce a poor quality cut on the edge surfaces of the substrate. It is always best to first make a rough cut and then a second finishing cut. This procedure can more easily be accomplished by attaching (with filament tape) a strip of laminate to the front side of the Template. (FIG. 3)

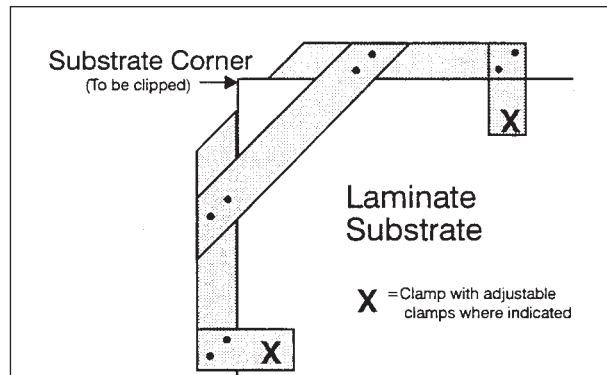

FIGURE 2

STEP 3

Make the first (rough cut) with the laminate between the router base and the Template. (FIG. 4) Then, flip-up the strip of laminate (using the tape as the hinge) and make the second (finishing) cut. The result will be a finish cut that is equal to one produced by the Straight Cut Planer. Complete the procedure by removing the Template from your countertop. Your "clipped" corner is now ready for the machining of the dado groove. Upon completion of that step, installation of the Decorative Edge moldings around the clipped corner can be easily accomplished by mitering the moldings with the 22-1/2° miter gauge.

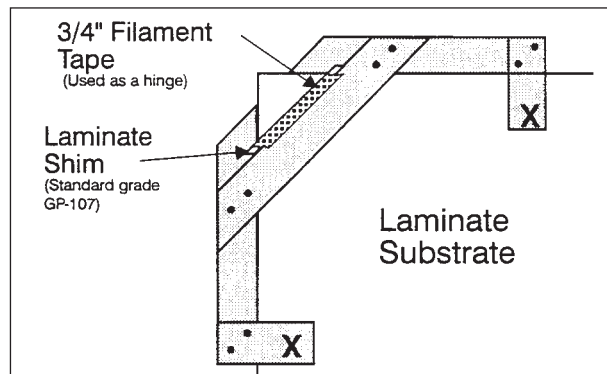

FIGURE 3

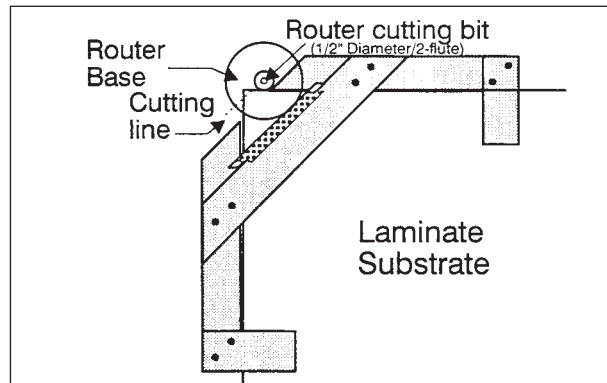

FIGURE 4

Wilsonart® Decorative Edges

Outside Radius Corners (Wood Moldings)

The Radius Corner Template provides an accurate method for the machining of exact 2", 4", and 6" outside radius corners. The Radius Corner Template is a useful and necessary tool when fabricating with Decorative Edge Solid Wood Moldings. Contact your Wilsonart distributor for ordering and pricing information.

The following steps will help assist you in fabricating Decorative Edge radius moldings.

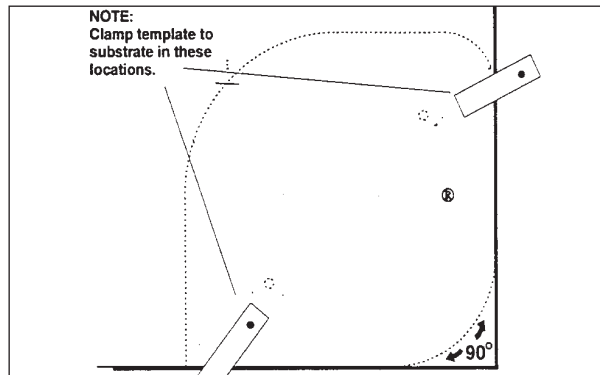

FIGURE 1

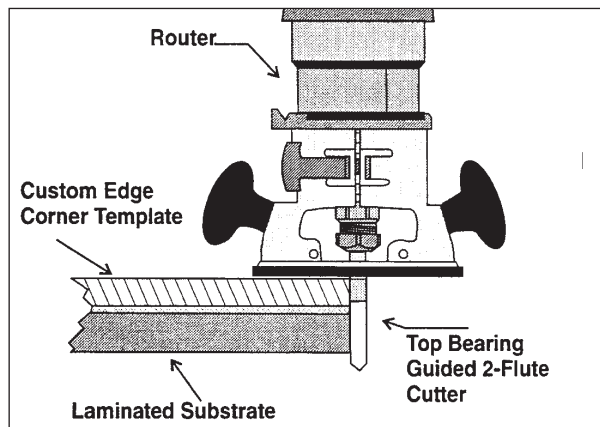

FIGURE 2

STEP 1

Straight cut plane the edges of the countertop.

NOTE: Be sure that countertop is square and flat.

STEP 2

Position the Radius Corner Template onto the countertop and draw line on countertop. (FIG. 1)

STEP 3

Remove the template and cut within 1/8" of the line with jig saw.

STEP 4

Position and clamp the Radius Corner Template onto the countertop. (FIG. 1)

NOTE: Make sure the template is flush with edges of countertop. If using bottom bearing bit, clamp template to bottom of countertop then follow steps.

STEP 5

Set the depth of the 1/2" top bearing guided, two flute cutter. (FIG. 2)

NOTE: Make sure bearing is positioned on template.

STEP 6

Machine the profile from left to right.

STEP 7

Remove template

STEP 8

You are now ready to cut dado. Refer to Adjustment Procedures For The 1/4" Dado Cutter in the Tool Setup section of this manual.

Inside Corners

The Decorative Edge product line utilizes a system approach for the fabrication of custom designed tops. The system provides precision high pressure decorative moldings and close tolerance solid wood moldings in various styles and designs, along with unique fabrication equipment, specifically designed to work within the molding tolerances. All of these are important elements that make the system work. For the past five years the inside corner has been a major concern in fabricating Wilsonart Decorative Edges. We have now designed a simple phenolic template that takes the guess work out of inside corners.

The inside corner phenolic templates are available through AMPS Edge in 45° and 90° angles (AMPS Interlocking Straight Edge System, 978-568-1127, ampsedge@verizon.net). The phenolic templates can assure quality fabrication by following these simple fabrication steps.

STEP 1

Oversize countertop by 1/8". Position inside corner template 1/8" from edge of countertop.

NOTE: Make sure you are 1/8" from the edge of the counter on both sides of template. (FIG. 1)

STEP 2

Clamp template into place. Using a mechanical pencil trace a line on the inside of the template. (FIG. 1)

NOTE: Double check your measurements to assure accuracy.

STEP 3

Use a router with a straight double flute bit and template guide to rout inside corner. (FIG. 2)
Remove inside corner template and feel edge for smoothness.

NOTE: Porter Cable, Template Guide #42046 (5/8")

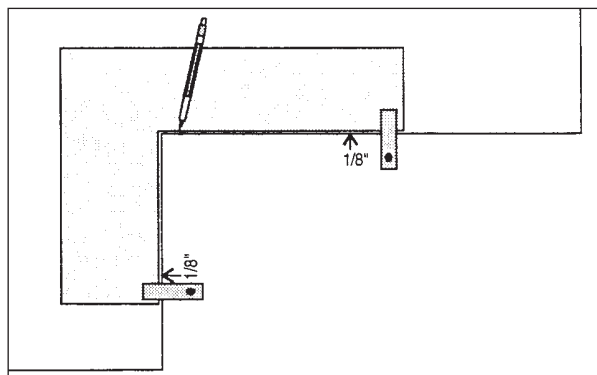

FIGURE 1

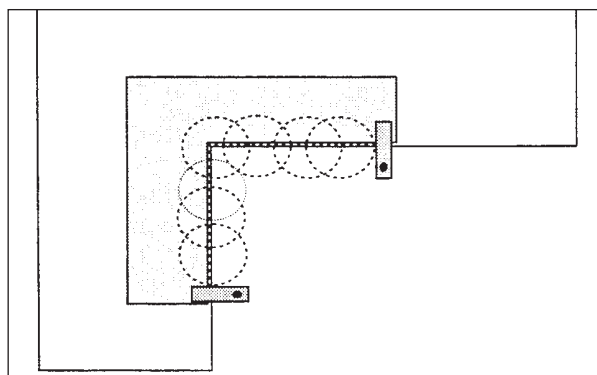

FIGURE 2

Wilsonart® Decorative Edges

Inside Corners

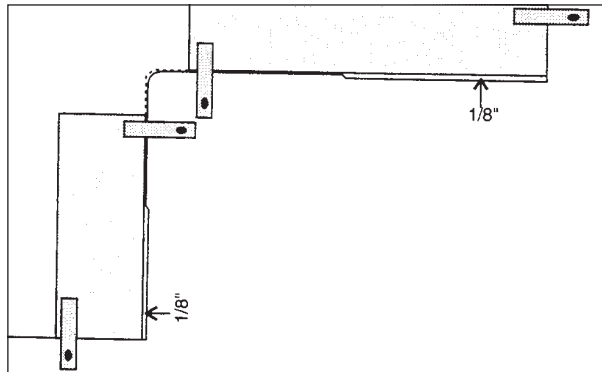

FIGURE 3

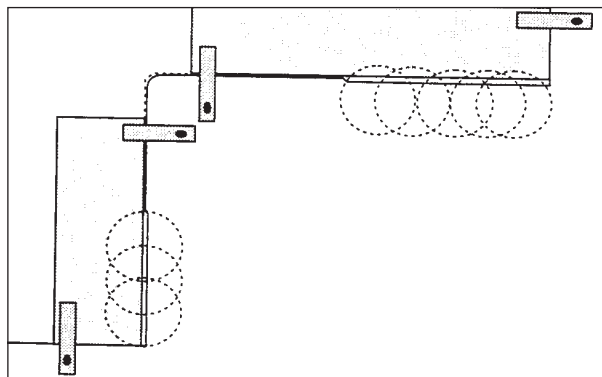

FIGURE 4

STEP 4

Take straight edge and align it with pencil mark on countertop. (FIG. 3)

NOTE: Make sure you are 1/8" away from edge at end of counter.

STEP 5

Clamp straight edge into place. (FIG. 3) Rout edge with Router, double flute bit and template guide. (FIG. 4)

STEP 6

Remove template and repeat steps 4 & 5.

STEP 7

If using SE-style moldings, you are now ready for your Dado cutter.

NOTE: The template guide causes a 1/16" separation between the bit and the guide. The 1/8" distance that you position your straight edge and inside corner template from the edge of the counter will allow you to trim 1/16" away from the substrate. This method will eliminate the use of the straight cut planer.

STEP 8

Cut and fit all moldings.

Wilsonart® Decorative Edges

AMPS Interlocking Template

The AMPS Interlocking Straight Edge System is a complete straight edge system that is designed to work with only two clamps no matter how long the run. Inside corners are no longer the time consuming hassle they have been in the past. The AMPS system eliminates all of the guess-work and time consuming fabrication steps currently involved in inside corner fabrication. By placing the AMPS system onto the work surface and applying one clamp at each end of the system, planing or routing can be done in one continuous step. The system includes:

- 1 31" Phenolic Straight Edge
- 1 48" Phenolic Straight Edge
- 1 96" Phenolic Straight Edge
- 1 Joining Plate (used to join two female ends)
- 1 90° Inside Corner Template
- 1 45° Inside Corner Template

Other sizes available. Call AMPS Edge (978-568-1127, ampsedge@verizon.net) for prices and availability.

Follow these steps to use the AMPS straight edge system with Decorative Edge Moldings.

STEP 1

Set AMPS system onto square prelaminate countertop for assembly. (Follow straight edge instructions for proper assembly)

STEP 2

Align system 1/8" from the edge of countertop. (FIG. 1)

STEP 3

Place one clamp at each end of countertop to hold the system into place. (FIG. 1)

STEP 4

Double check measurements to assure accuracy.

STEP 5

Place router (with two fluted cutter and template guide Porter Cable #42046) onto straight edge and rout the front edge of the countertop. (Always rout from left to right) (FIG. 2)

STEP 6

Remove clamps and straight edge system.

STEP 7

You are now ready for the dado cut.

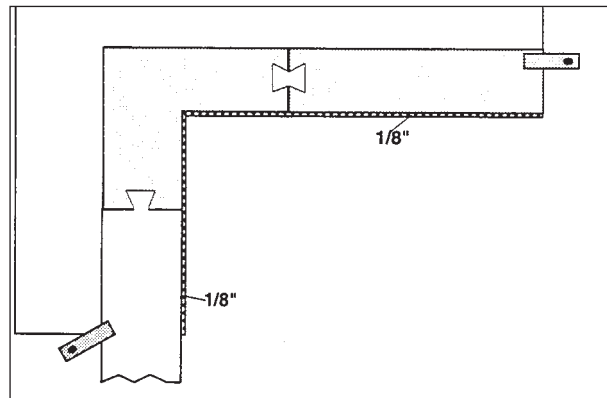

FIGURE 1

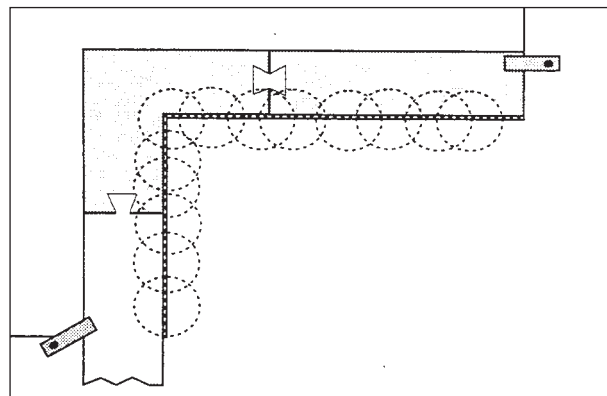
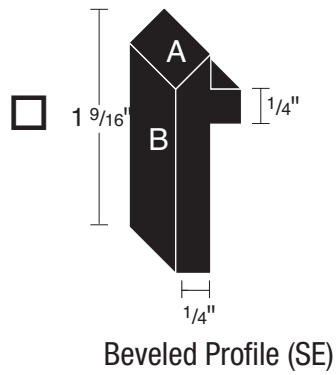
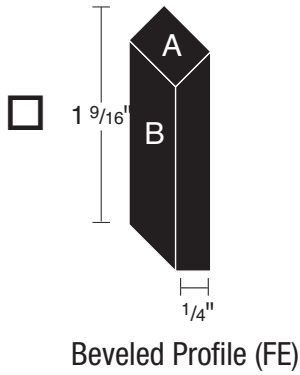

FIGURE 2

Decorative Edge Profiles

Laminate (FE, SE)

When ordering, specify profile type and pattern/finish for each face.



Face A.

_____ Pattern/Finish

Face B.

_____ Pattern/Finish

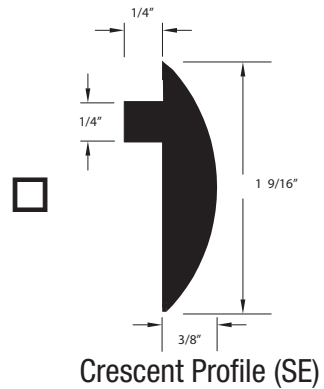
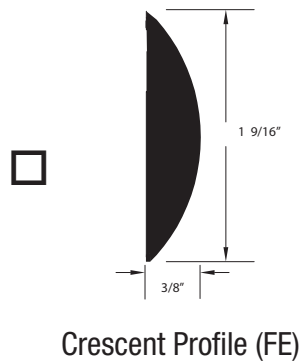
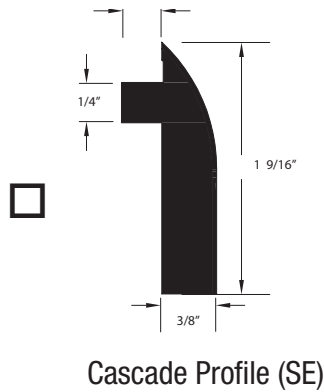
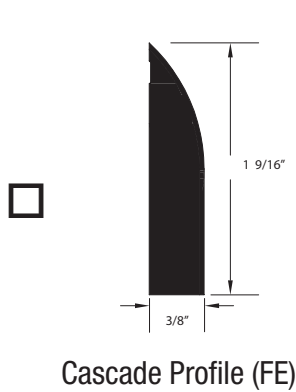

Decorative Edge Profiles

Solid Wood (HT, KT)

Wood Style - HT-1, HT-11, KT-1

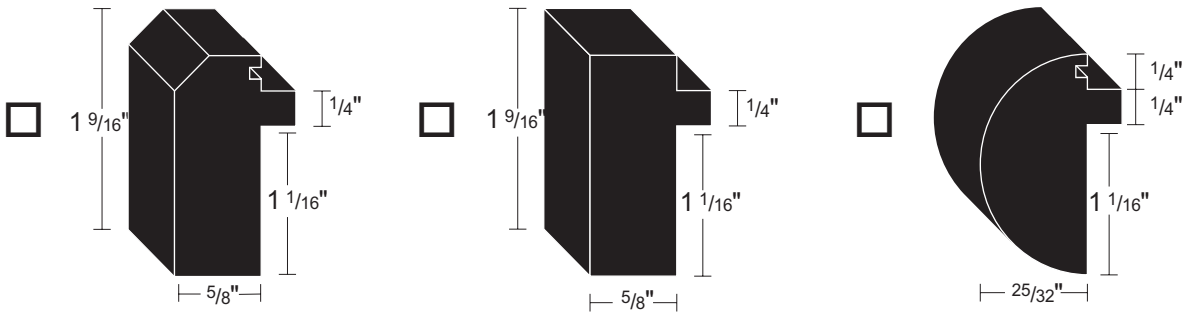

Lengths: 144"
Profile (HT-1) 3/8" Bevel Top

Lengths: 144"
Profile (HT-11) Square

Lengths: 144"
Profile (KT-1)
1 9/16" Half Round

Available Species*: Red Oak Hard Maple

Also available without tongues:

- HN1RO Bevel (Red Oak)
- HN11RO Square (Red Oak)
- KN1HM Half Round (Hard Maple)

Wood (Rounded Corner) Style - RHT-1, RHT-11, RKT-1

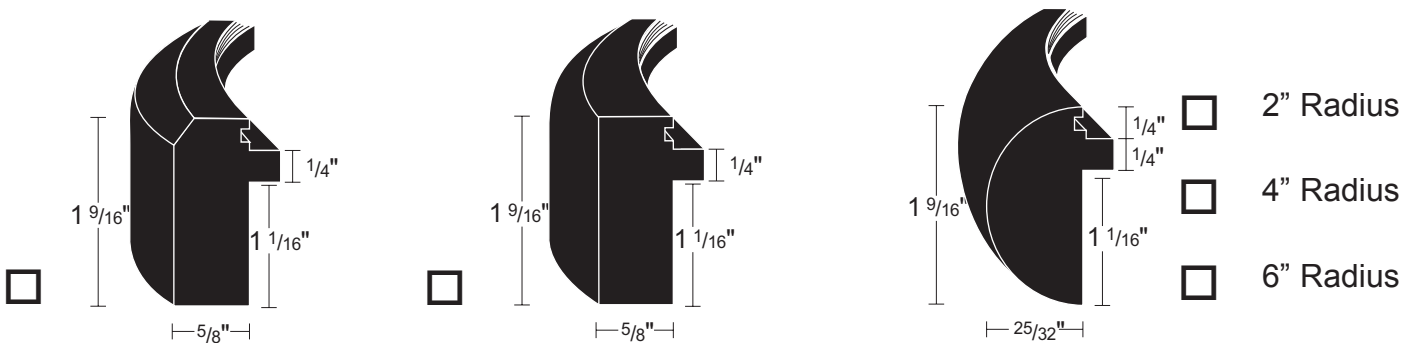

Lengths: 2" radii
Profile (RHT-1) Rounded
Corner 3/8" Bevel Top

Lengths: 2" radii
Profile (RHT-11) Rounded
Corner 3/8" Square Top

Lengths: 2, 4, and 6" radii
Profile (RKT-1) Rounded
Corner 1 9/16" Half Round

Available Species*: Red Oak Hard Maple

- * Special order species: Cherry, White Oak, White Birch and Black Ash.
 Minimum order quantity: 10 each 12' length molding per specie and style.
 Lead time: 4 to 6 weeks.
 Call your Wilsonart distributor for a price quotation.